



HEI MAKERS

# WORKSHOP #1

3D modeling low to medium complexity parts



Co-funded by the  
Erasmus+ Programme  
of the European Union  
2017-1-LT01-KA203-035231

# 3D MODELING LOW TO MEDIUM COMPLEXITY PARTS

- The aim of the workshop is to train the makers in using a 3D CAD software, namely CATIA V5, for modelling parts using specific tools and parameterization. Generative Surface Design module is also presented so that makers to acquire knowledge on how to create surface models.
- Resources / Tools needed: 3D CAD software – CATIA V5, computers/laptops.
- Prerequisites: basic knowledge on how to model a 3D part using CATIA V5

Duration	4 academic hrs
Author / Lecturer	Diana Popescu, UPB-CAMIS
Delivery methods	Individual
Evaluation methods	Evaluation of the completed 3D parts

## 3D MODELING A PARAMETERIZED PART IN CATIA V5 (1/14) – EXAMPLE 1

- Several steps will be explained further for 3D modeling and parameterizing a box. Detailed instructions can be found by accessing the file: [3D\\_CV5\\_box\\_bottle.pdf](#).

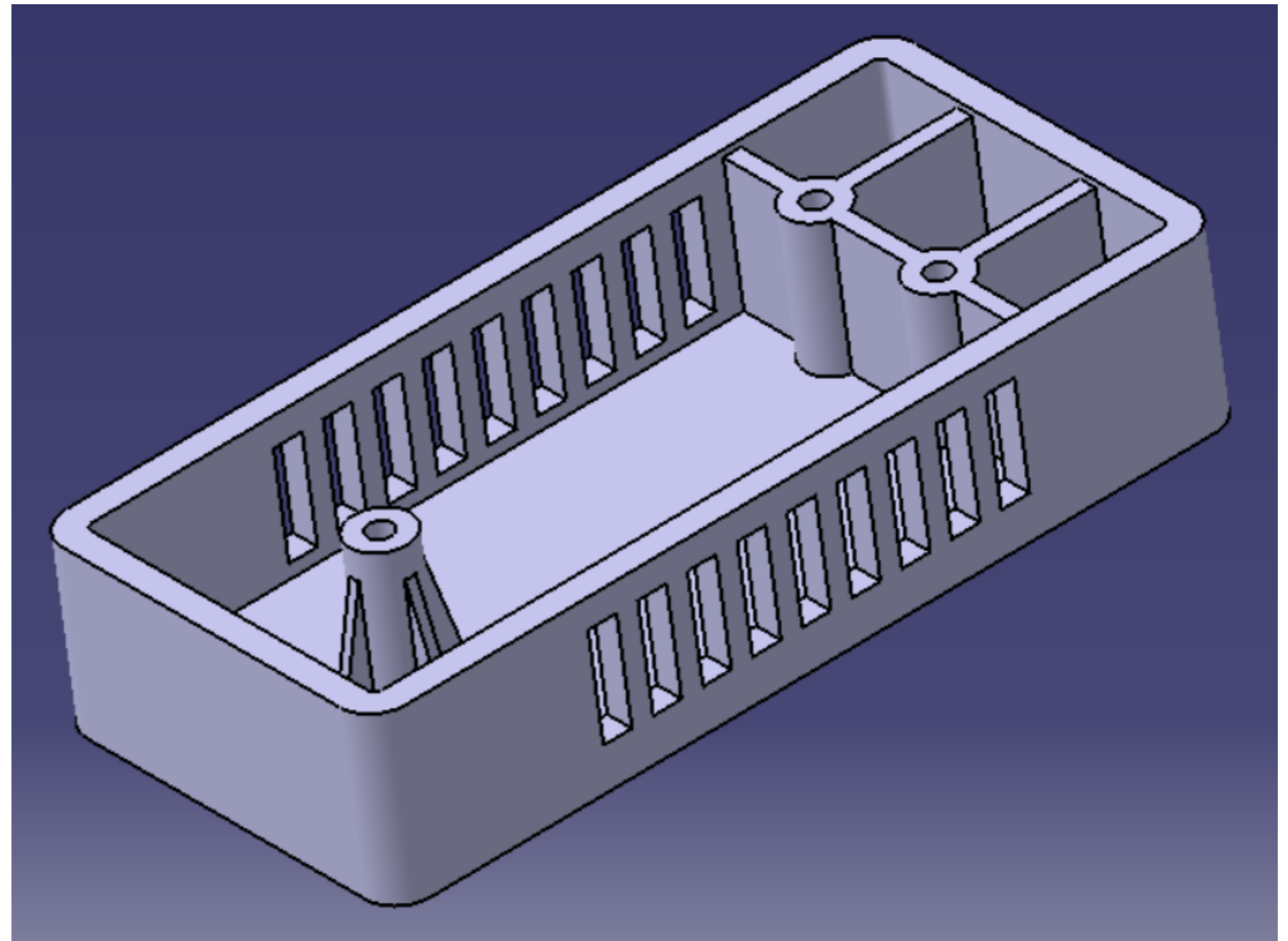
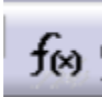
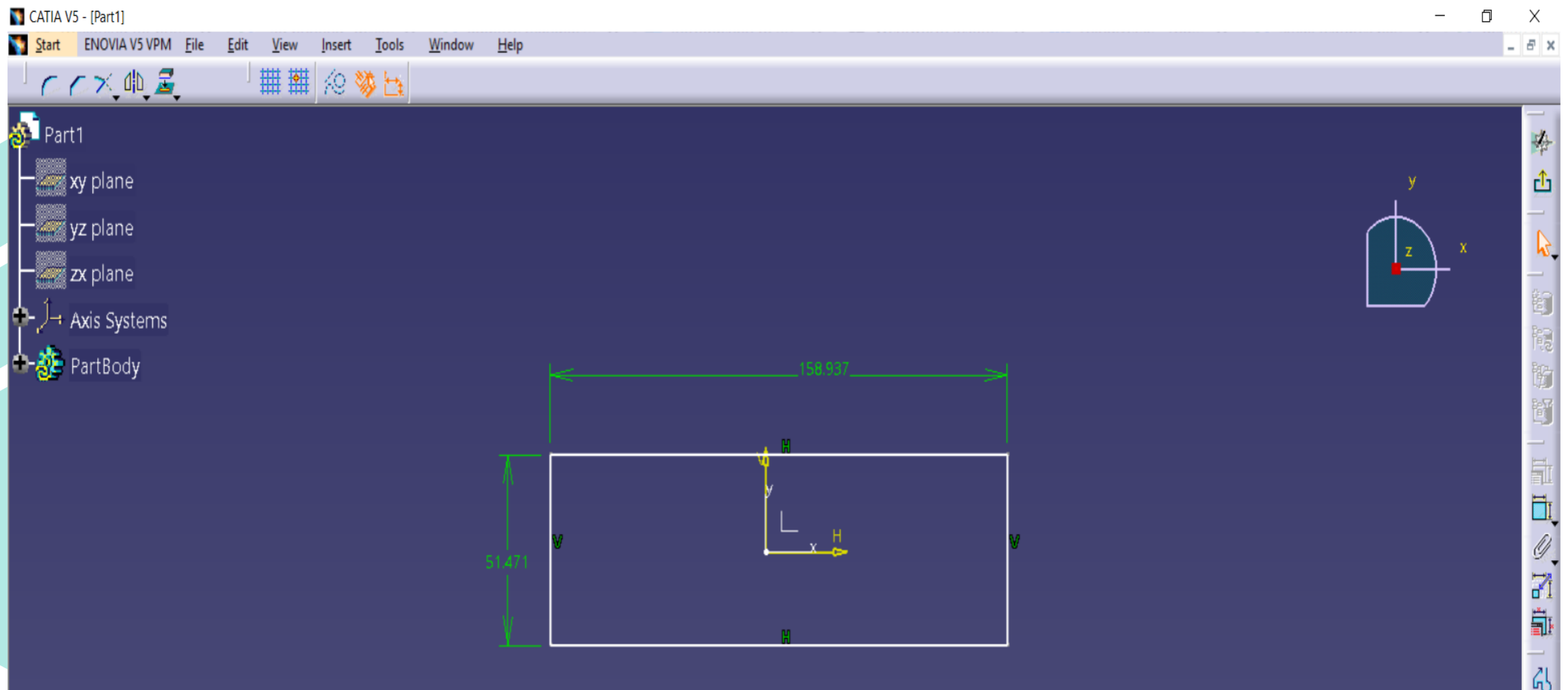

Figure 8.1 Box to be modeled

# 3D MODELING A PARAMETERIZED PART IN CATIA V5 (2/14) – EXAMPLE 1

- Define formulas: 
- Enter Sketch workbench, draw and dimensional constraint a rectangle



# 3D MODELING A PARAMETERIZED PART IN CATIA V5 (3/14) – EXAMPLE 1

- Right click on the constraint value for accessing contextual menu and press Edit formula
- Add a formula for rectangle width using Formula editor, then press OK.

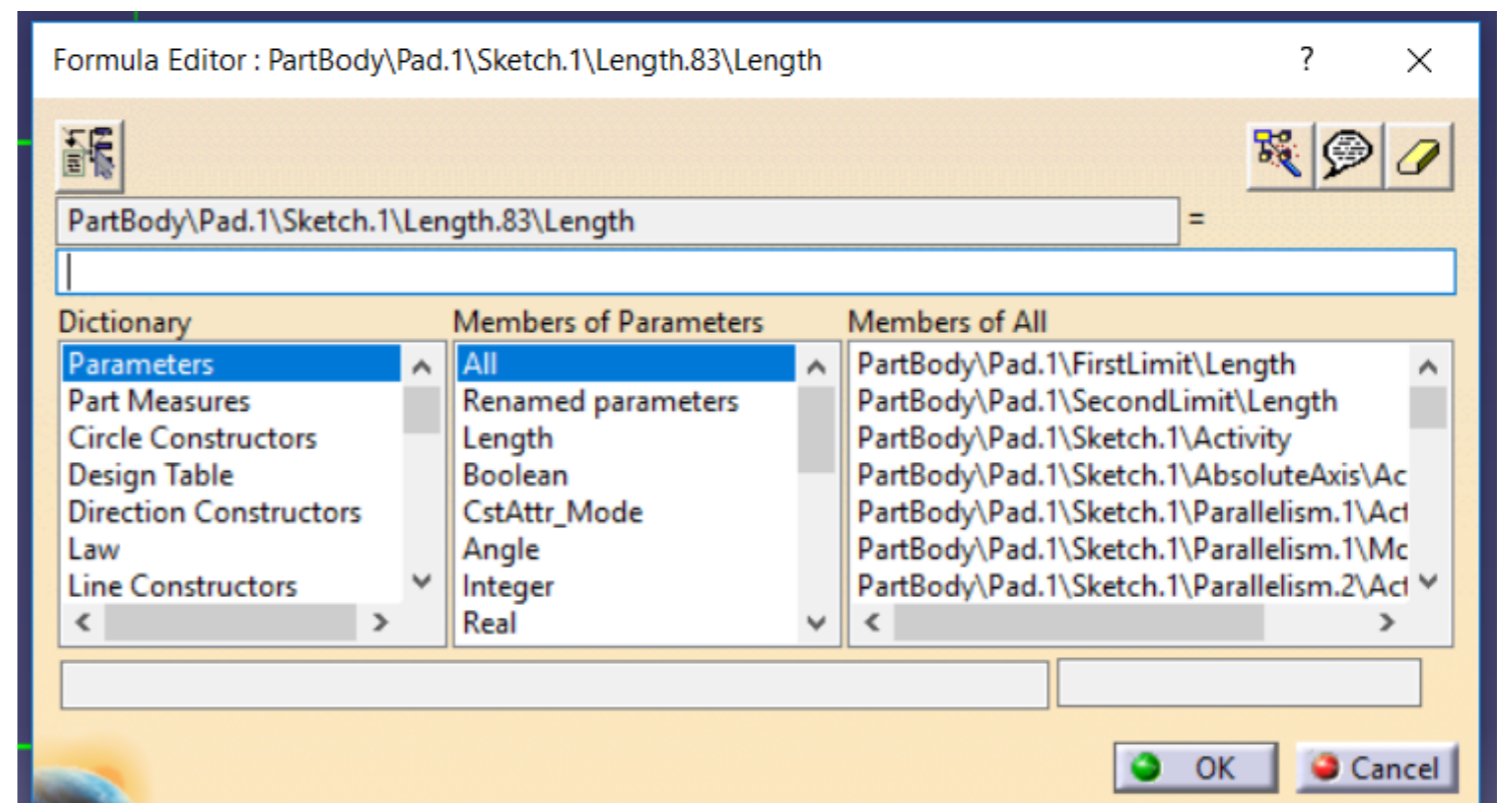
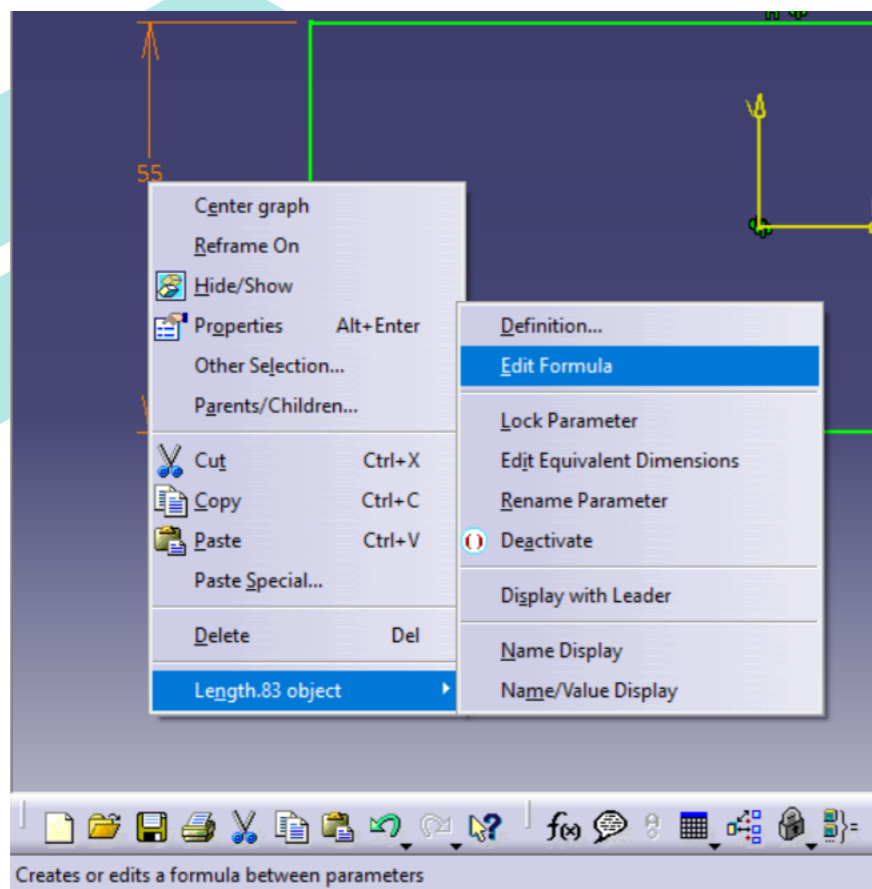

# 3D MODELING A PARAMETERIZED PART IN CATIA V5 (4/14) – EXAMPLE 1

- Depending on functional requirements and/or on the 3D printer building volume, one can set new values for the two parameters (length -Lungime and width-Latime) and also for the height of the box, which can be defined in the same manner.

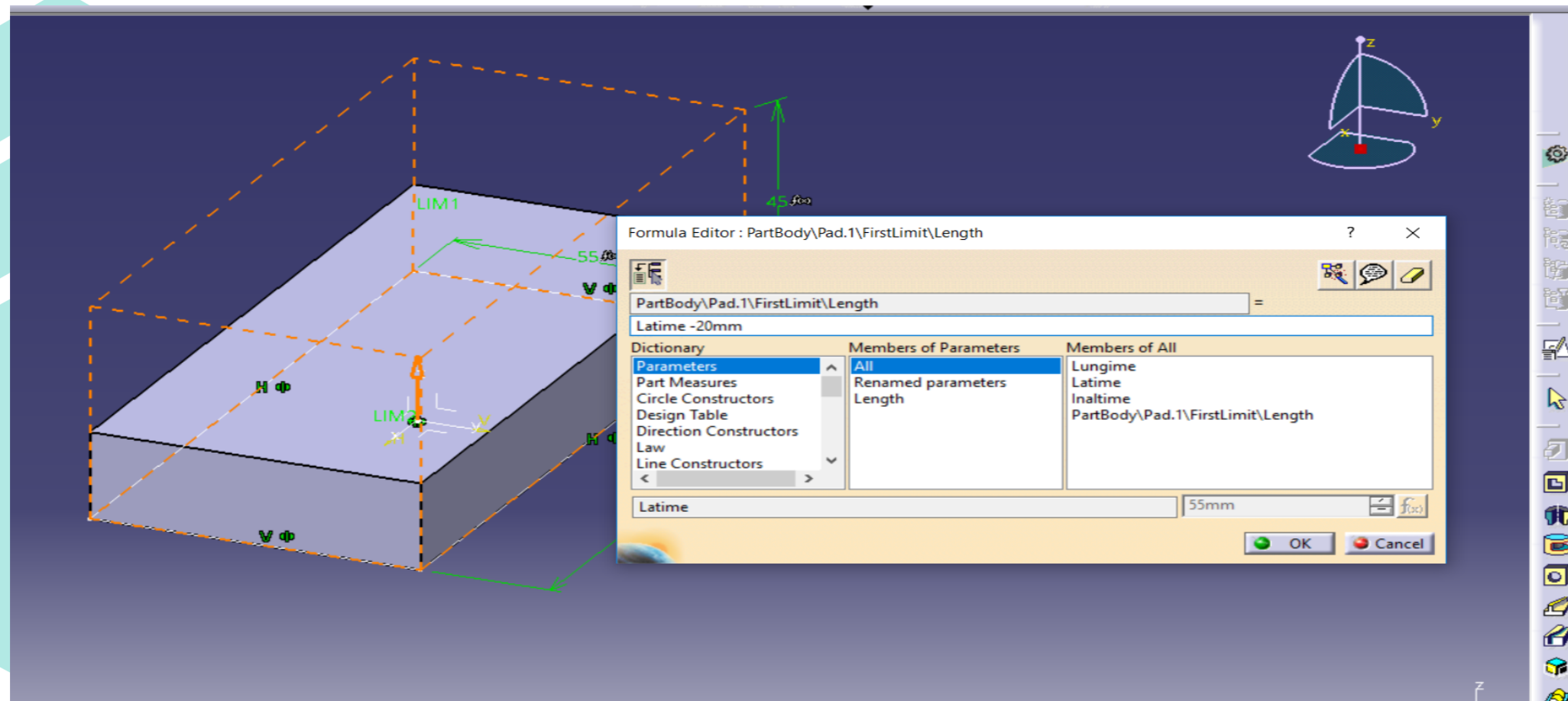

# 3D MODELING A PARAMETERIZED PART IN CATIA V5 (5/14) – EXAMPLE 1

- Modify the values of parameters from the specification tree and observe the changes.

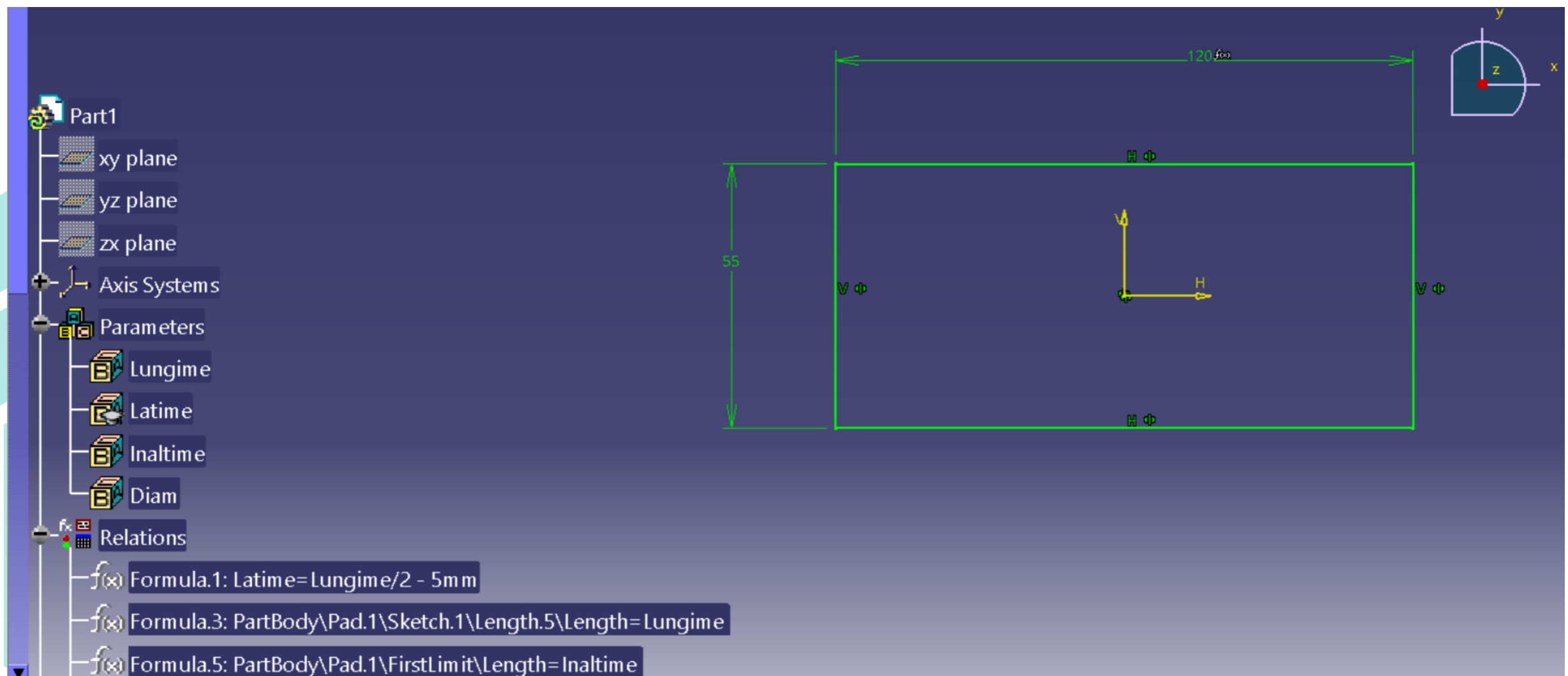

# 3D MODELING A PARAMETERIZED PART IN CATIA V5 (6/14) – EXAMPLE 1

- Shell the box. Consider the functionality of the part and also the minimal wall thickness that can be built using FDM process on your 3D printer.
- What if 10mm radius is prescribed for the box edges? Compare with 10 mm chamfer ?
  - Remember: fillets or overhangs (more than 45deg) can be eliminated by a simple chamfer at 45deg if they don't have a functional purpose.

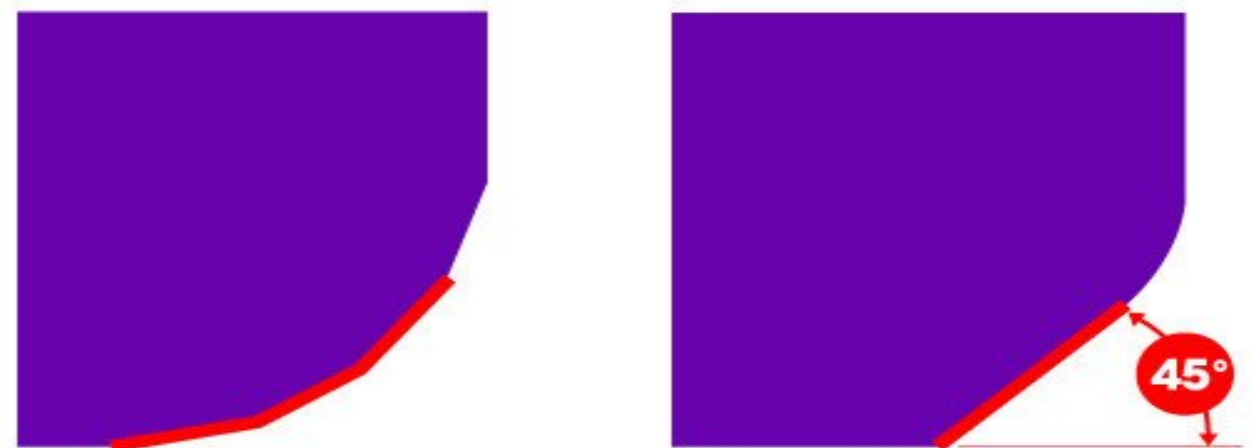



# 3D MODELING A PARAMETERIZED PART IN CATIA V5 (7/14) – EXAMPLE 1

- Model box reinforcement using Stiffener option (From top, 2.5mm thickness). Create a formula so that all that all holes diameters to be equal with a parameter called Diam.

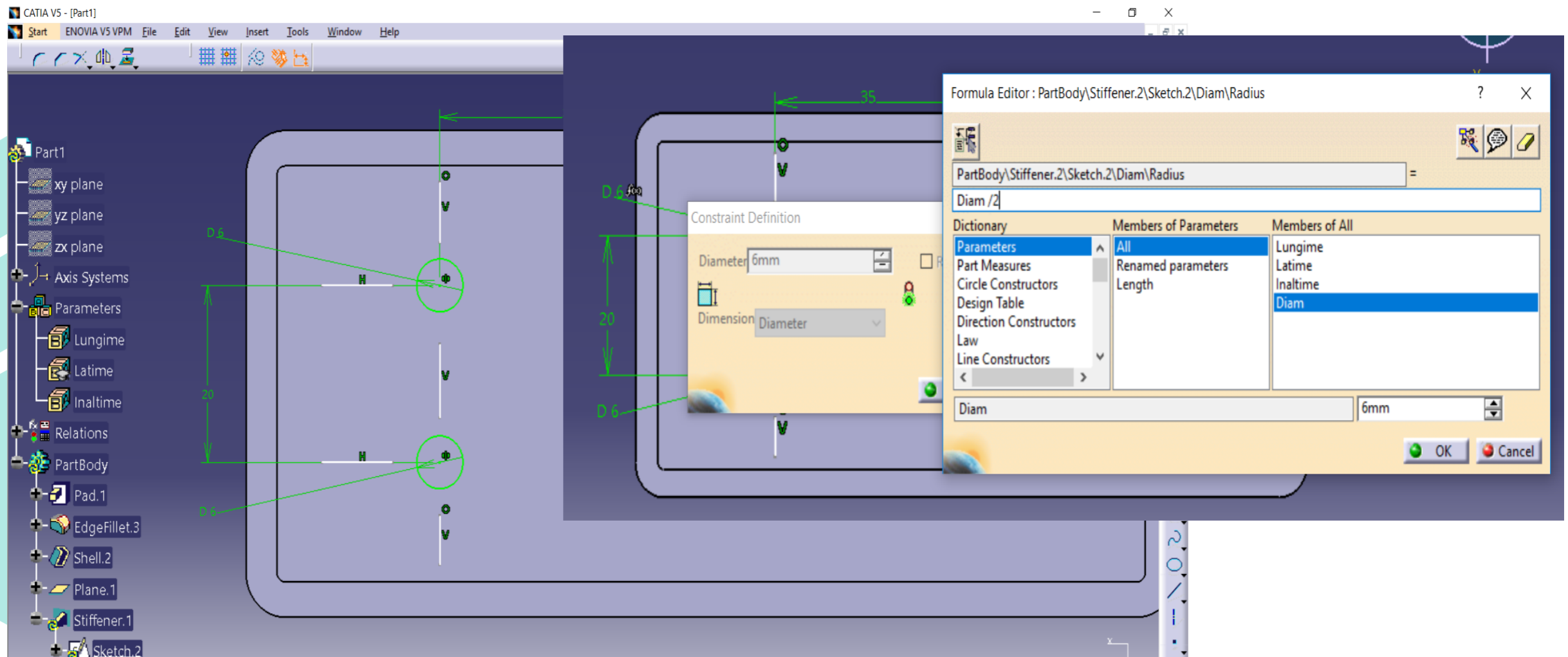

# 3D MODELING A PARAMETERIZED PART IN CATIA V5 (8/14) – EXAMPLE 1

- This is the result.

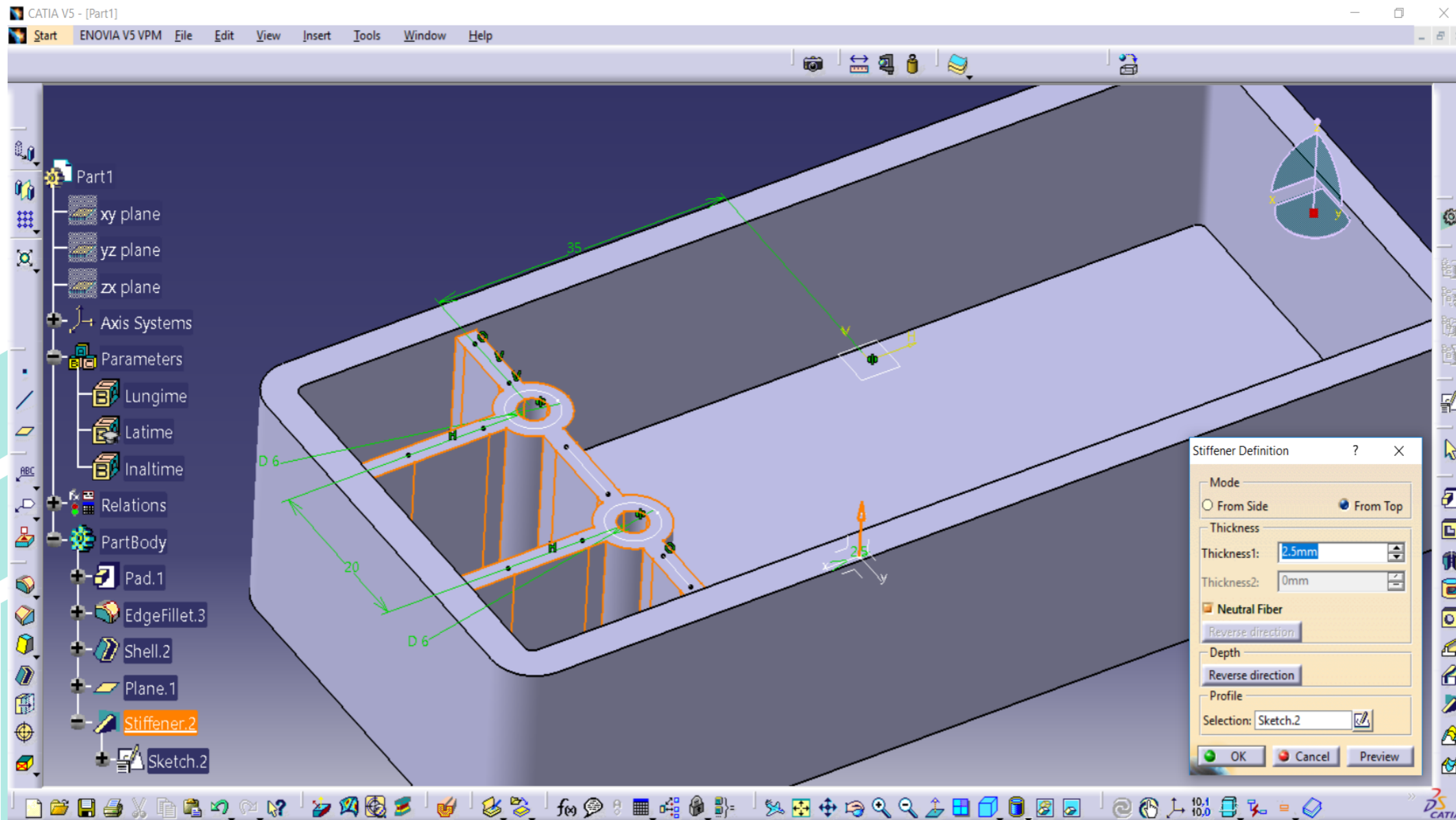

# 3D MODELING A PARAMETERIZED PART IN CATIA V5 (9/14) – EXAMPLE 1

- Do the same for creating reinforcements for the cylindrical feature.
- Multiply them using Circular Pattern option

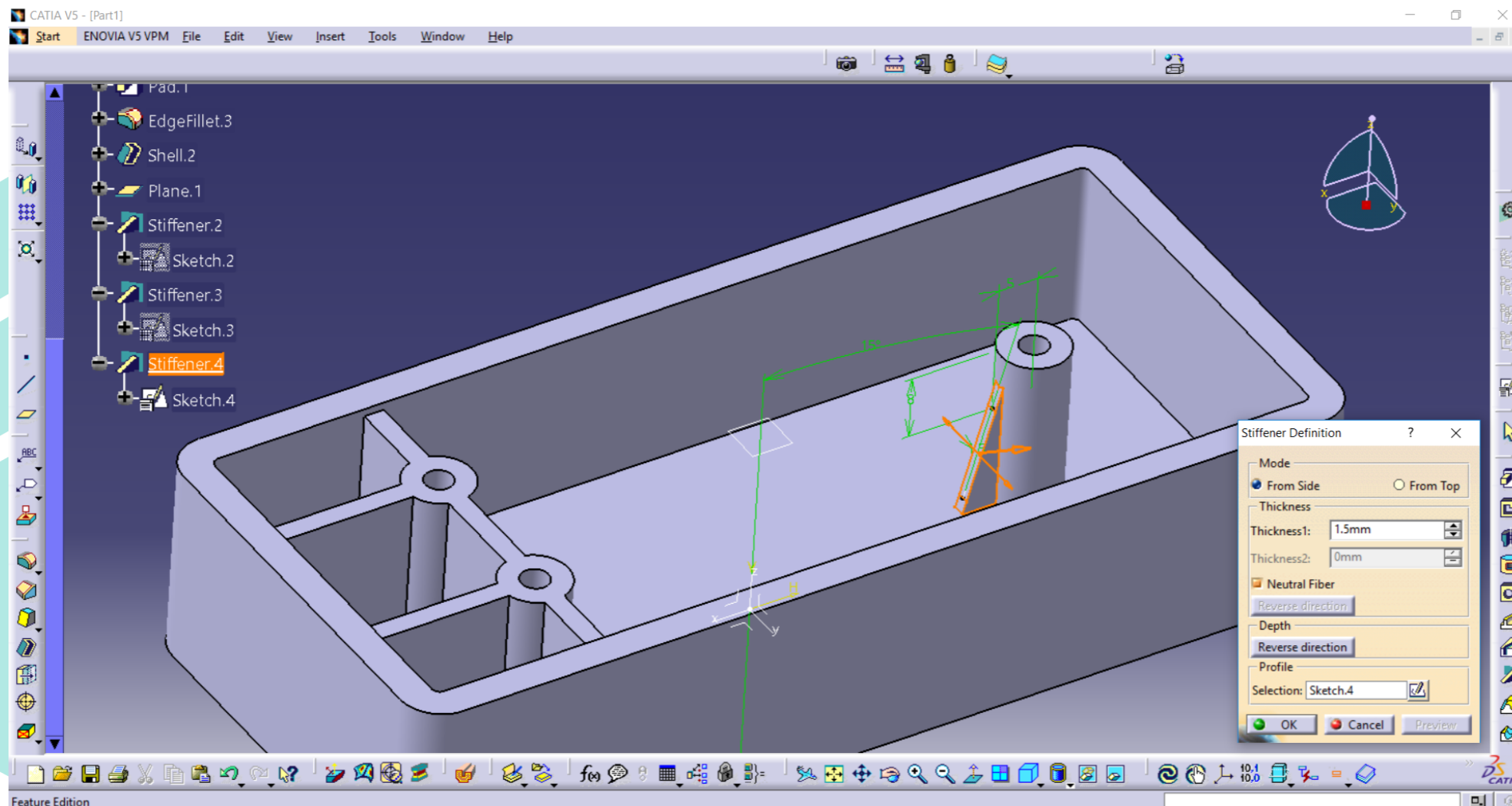

# 3D MODELING A PARAMETERIZED PART IN CATIA V5 (10/14) – EXAMPLE 1

- Create and multiply (Rectangular Pattern) pockets in the part.
- If you placed the slot as in figure, use More option for creating pockets on each side of the pocket.

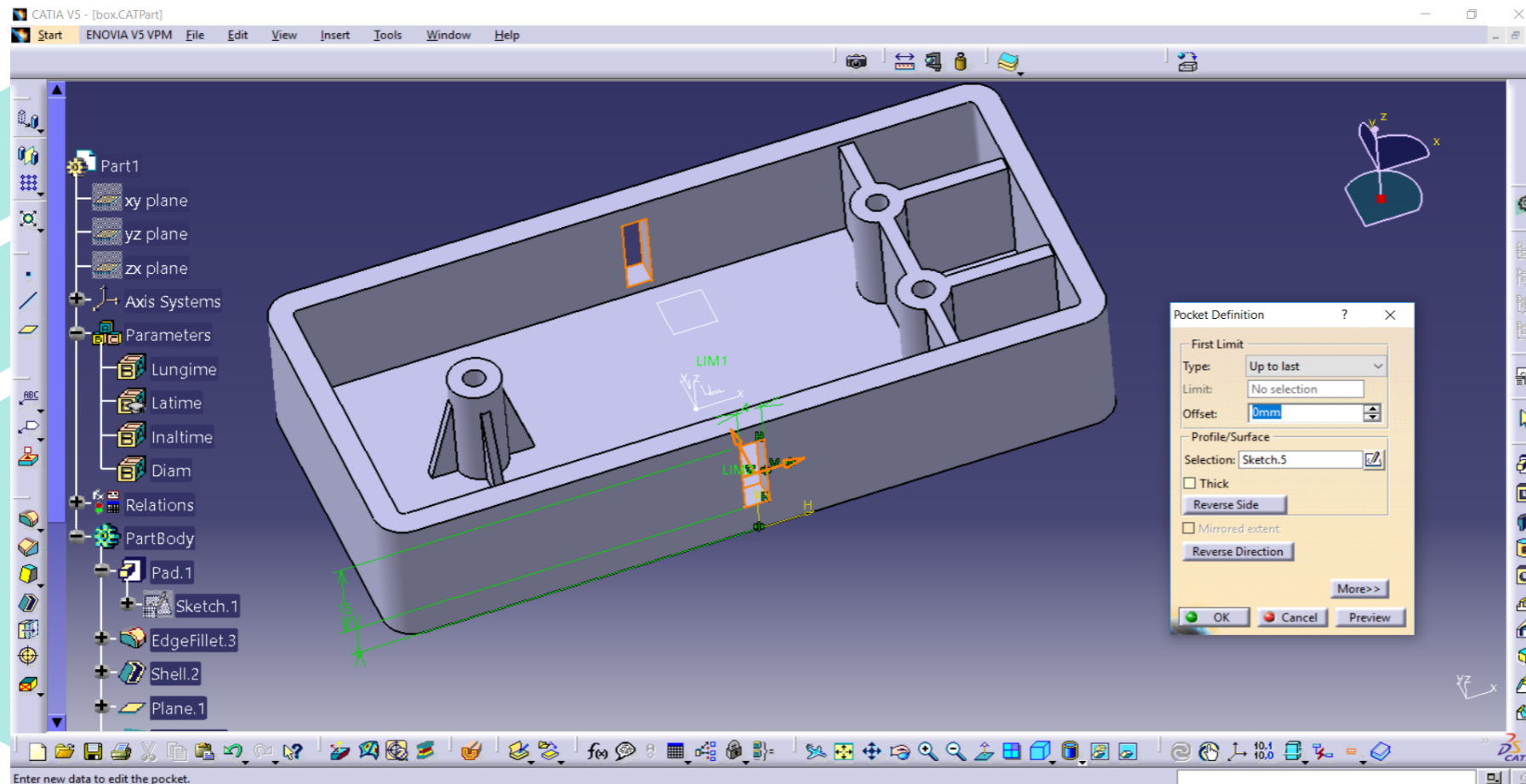

# 3D MODELING A PARAMETERIZED PART IN CATIA V5 (11/14) – EXAMPLE 1

- For that use More option from Rectangular Pattern dialog box.

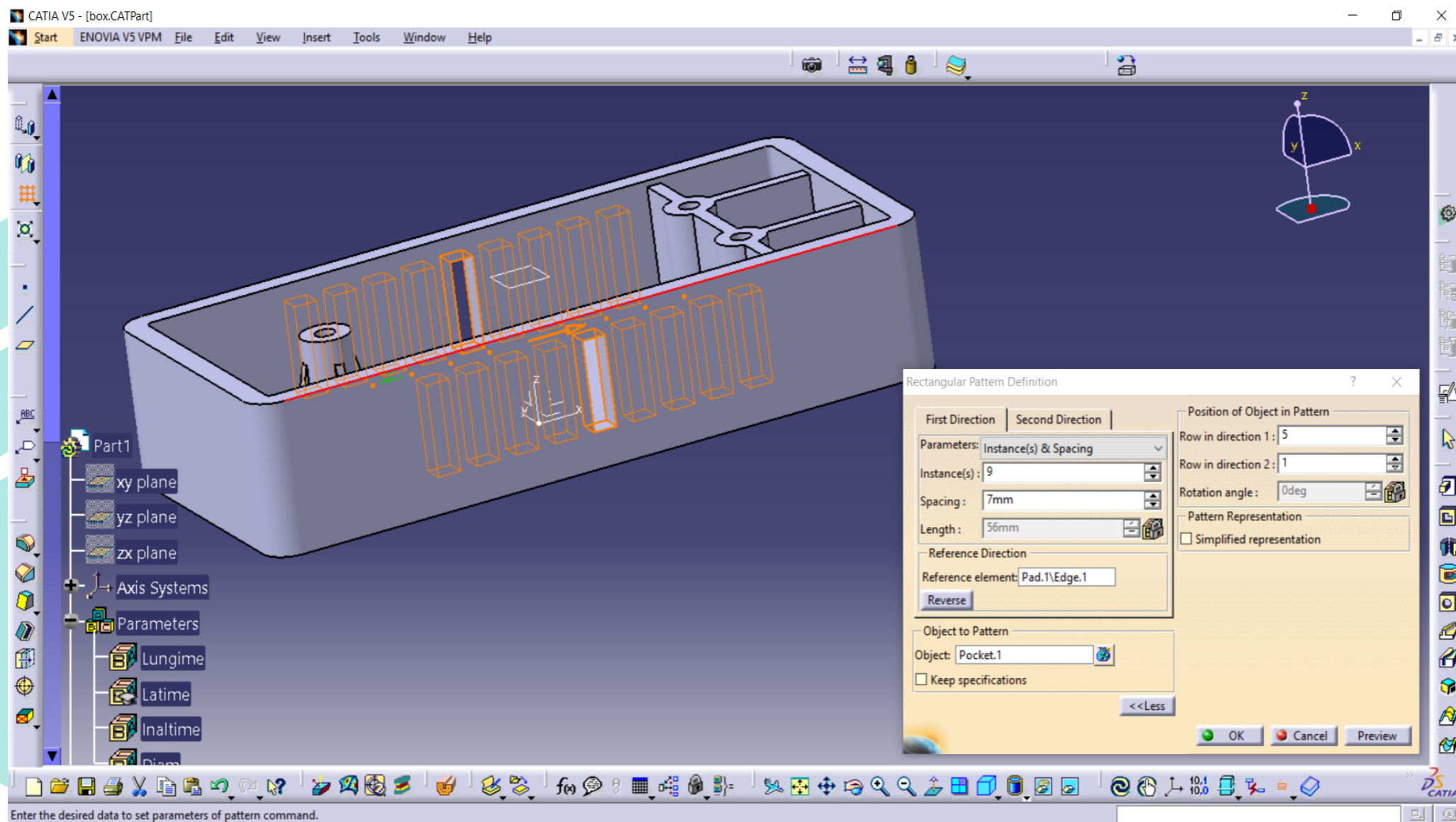

# 3D MODELING A PARAMETERIZED PART IN CATIA V5 (12/14) – EXAMPLE 1

- Establish a design rule using Knowledge Advisor benchmark in CV5 for displaying a message if an user is changing the value of Diam parameter (which equal with the diameter of all holes in part) is smaller than 2 mm.

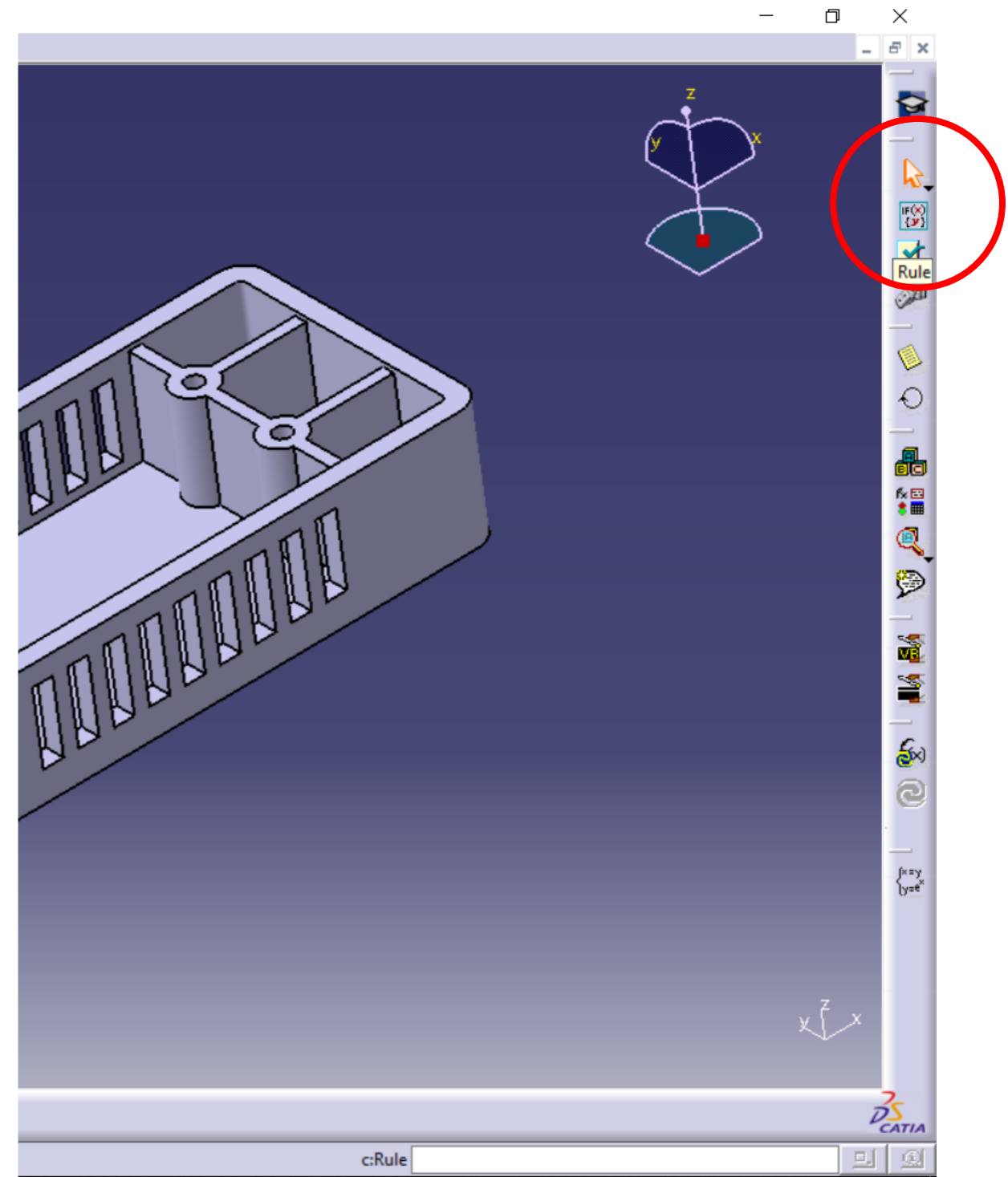

# 3D MODELING A PARAMETERIZED PART IN CATIA V5 (13/14) – EXAMPLE 1

- Press Rule icon and name the rule. Then create rule:
- *if PartBody\Stiffener.2\Sketch.2\Diam\Radius < 2mm*
- *{Message ("This diameter is too small for 3D printing")}*

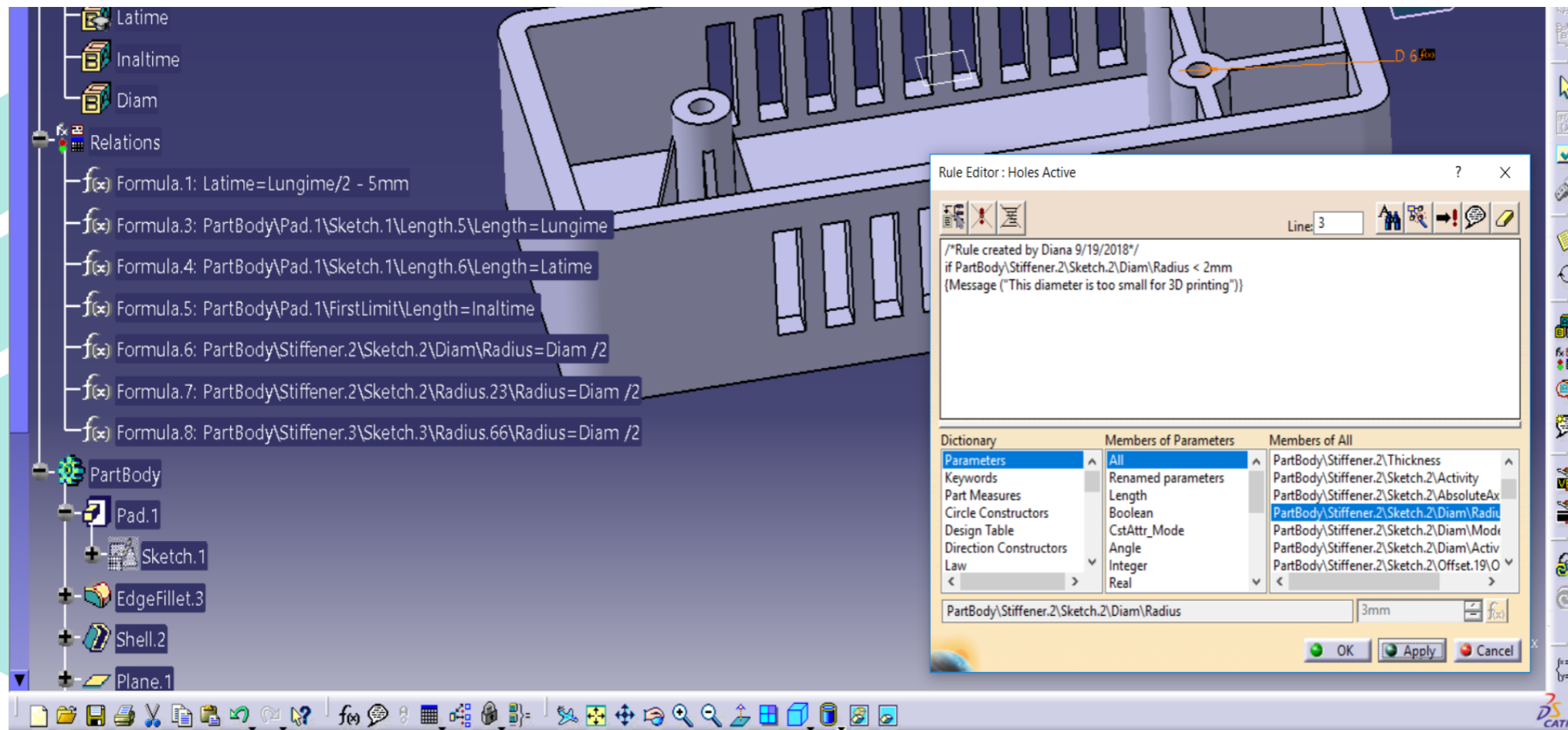

# 3D MODELING A PARAMETERIZED PART IN CATIA V5 (14/14) – EXAMPLE 1

- Such rules can be set for a part overall dimensions to ensure their suitability for a certain 3D printer building volume.

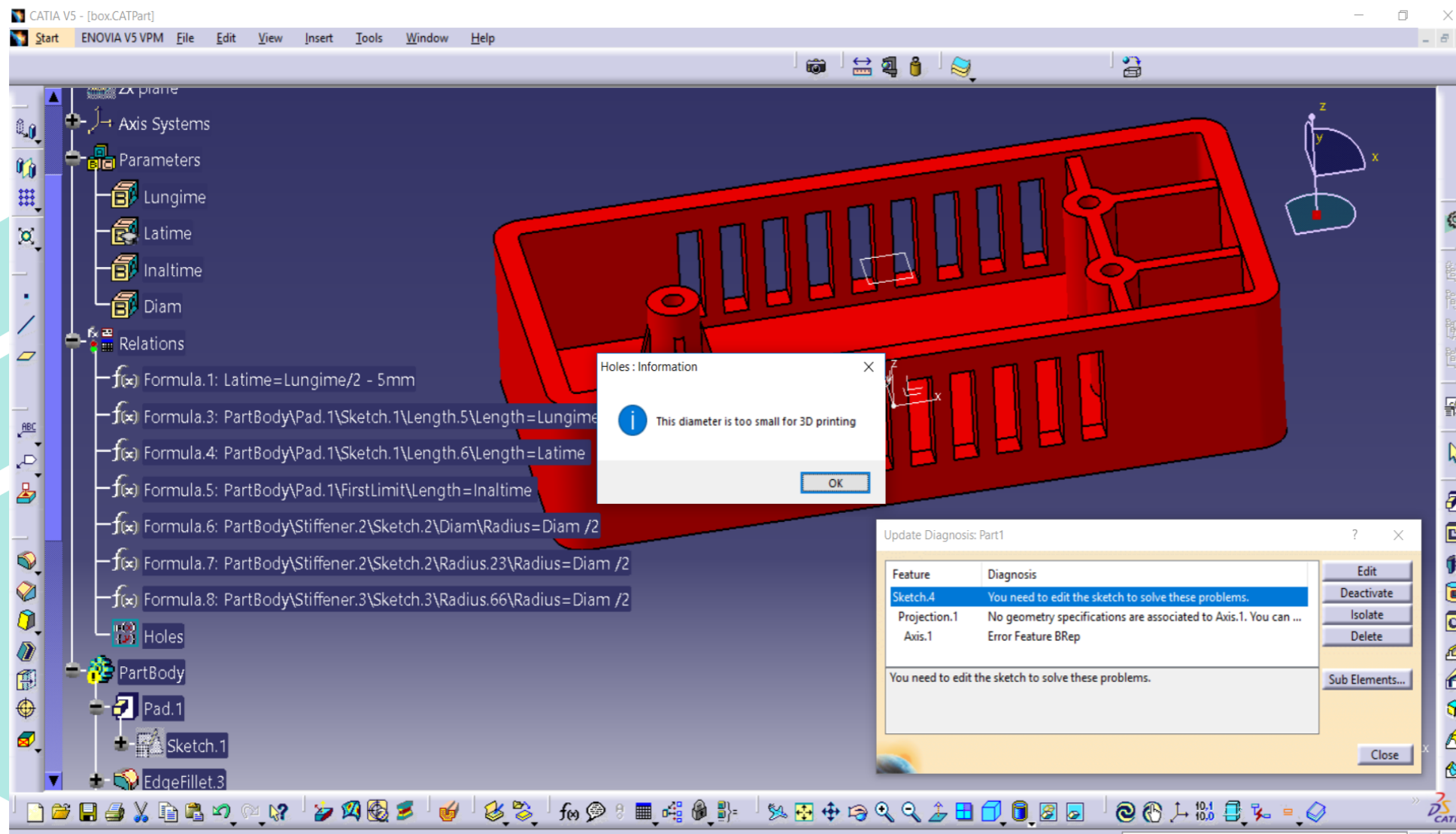



# 3D MODELING A PARAMETERIZED PART IN CATIA V5 (1/8) – EXAMPLE 2

- Let's model a bottle using Generative Surface Design workbench in CATIA V5.
- For detailed instructions access the file: [3D\\_CV5\\_box\\_bottle.pdf](#).

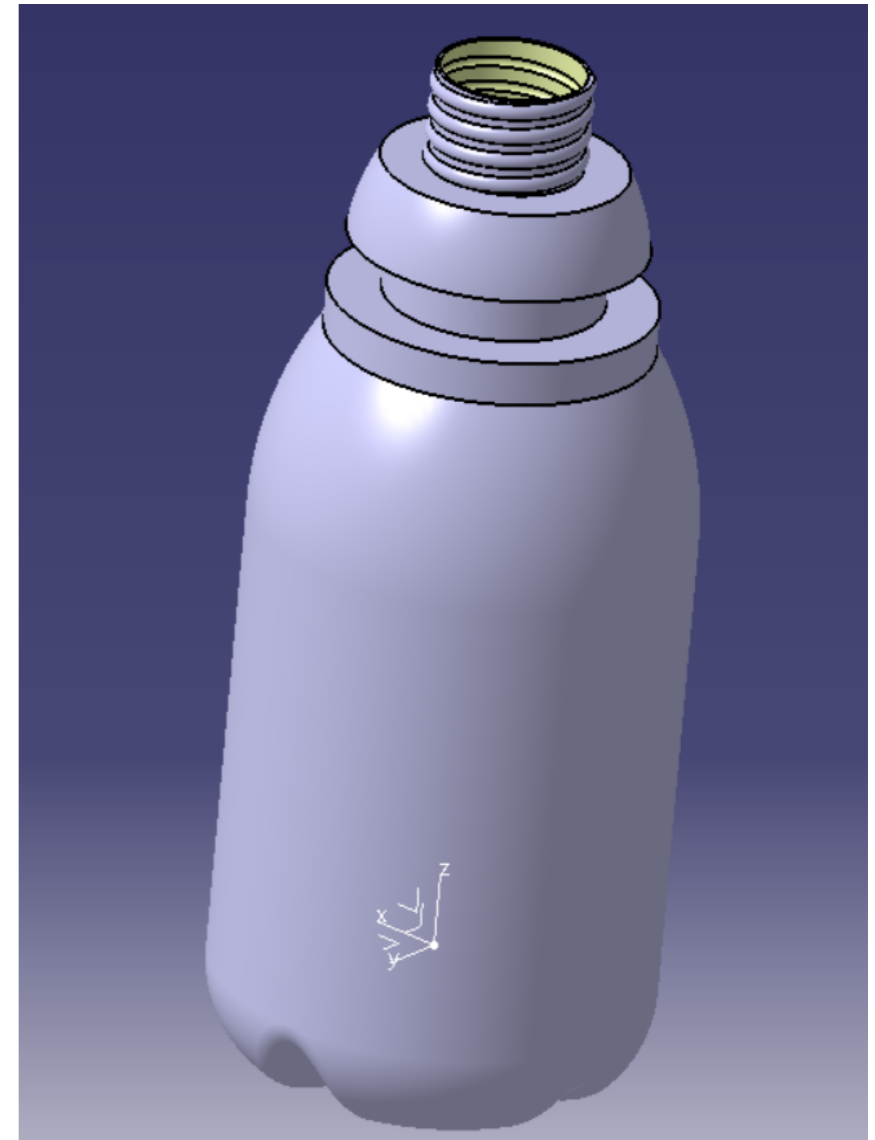

# 3D MODELING A PARAMETERIZED PART IN CATIA V5 (2/8) – EXAMPLE 2

- Draw and constrain a sketch in yz plane. Then rotate it around z axis – Revoluted option, 180 deg.
- Create a plane as 10mm offset from plane yz. Draw a sketch on the new plane.

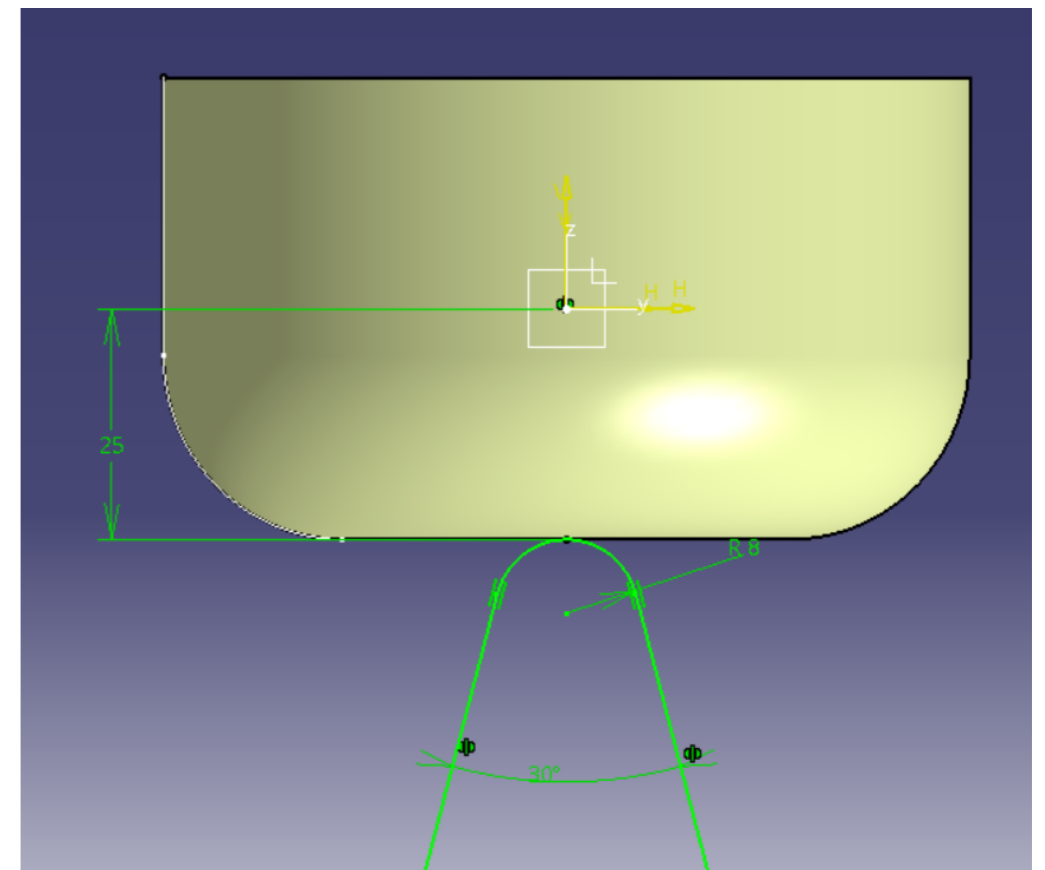
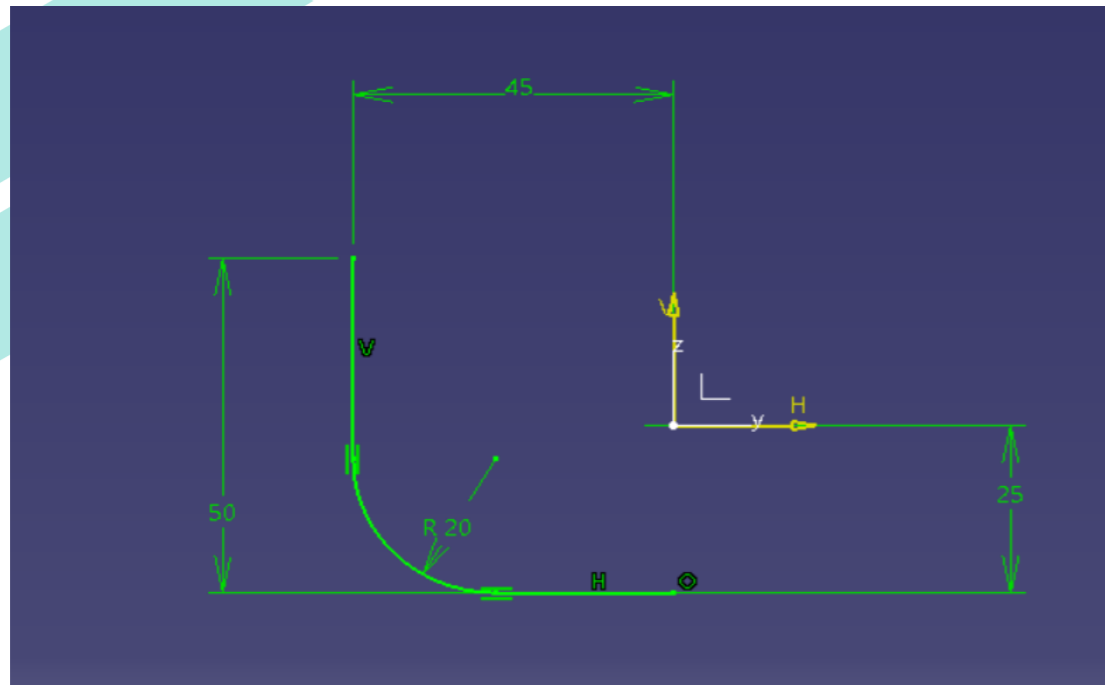

# 3D MODELING A PARAMETERIZED PART IN CATIA V5 (3/8) – EXAMPLE 2

- Create a new sketch on zx plane.
- Use Sweep option.

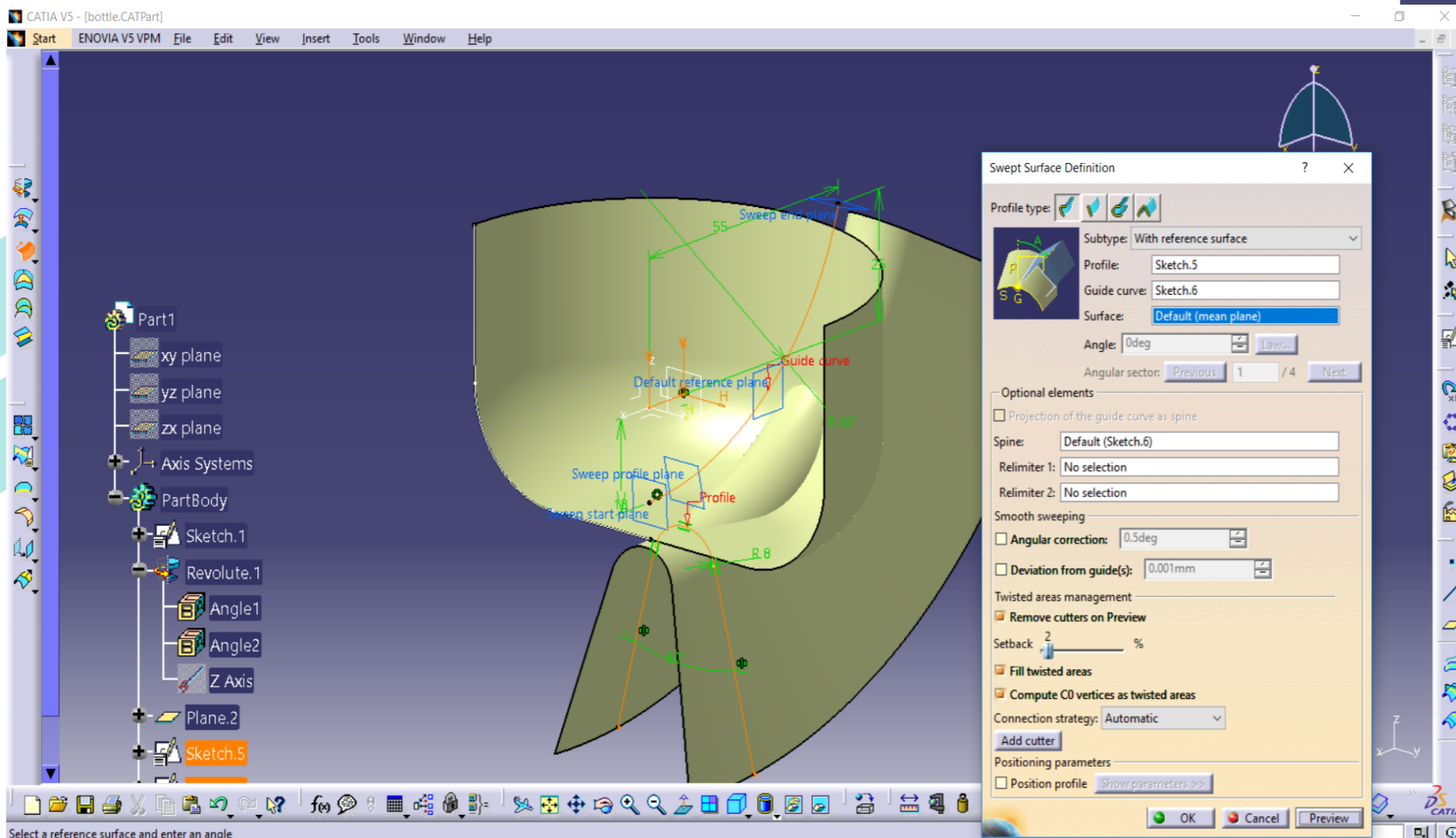
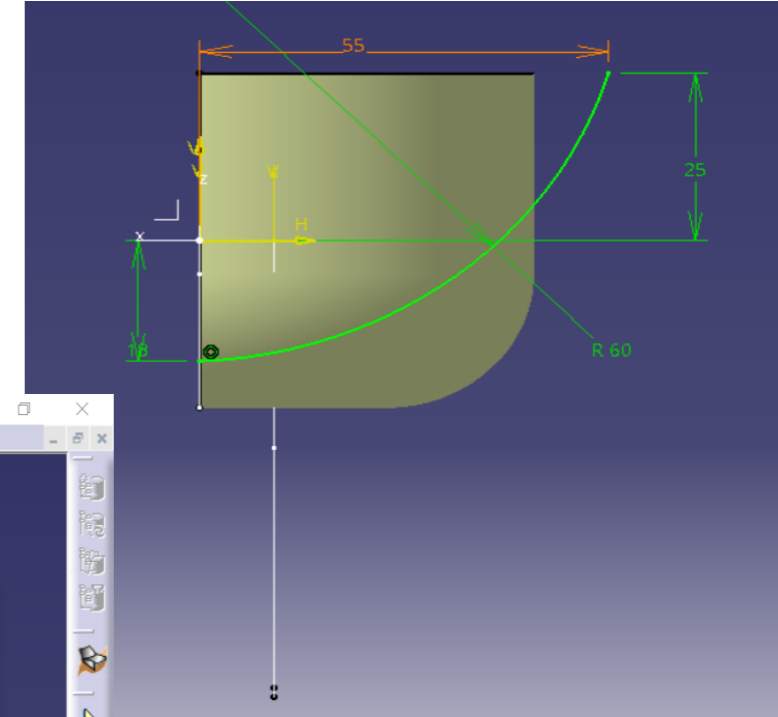

# 3D MODELING A PARAMETERIZED PART IN CATIA V5 (4/8) – EXAMPLE 2

- Apply Circular Pattern option for Sweep.1 surface.  
Trim all surfaces.

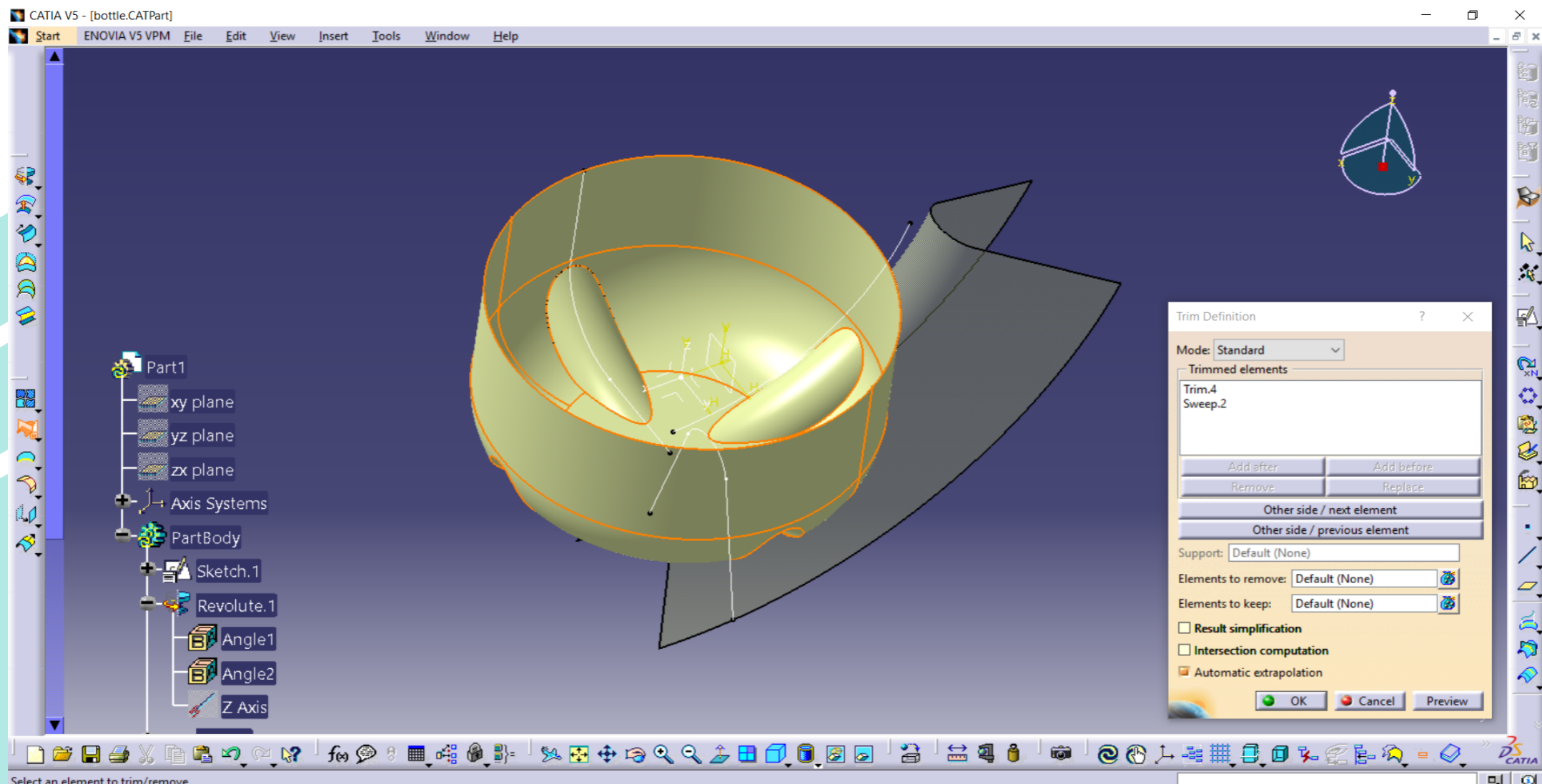

# 3D MODELING A PARAMETERIZED PART IN CATIA V5 (5/8) – EXAMPLE 2

- Fillet edges with 5 mm radius.

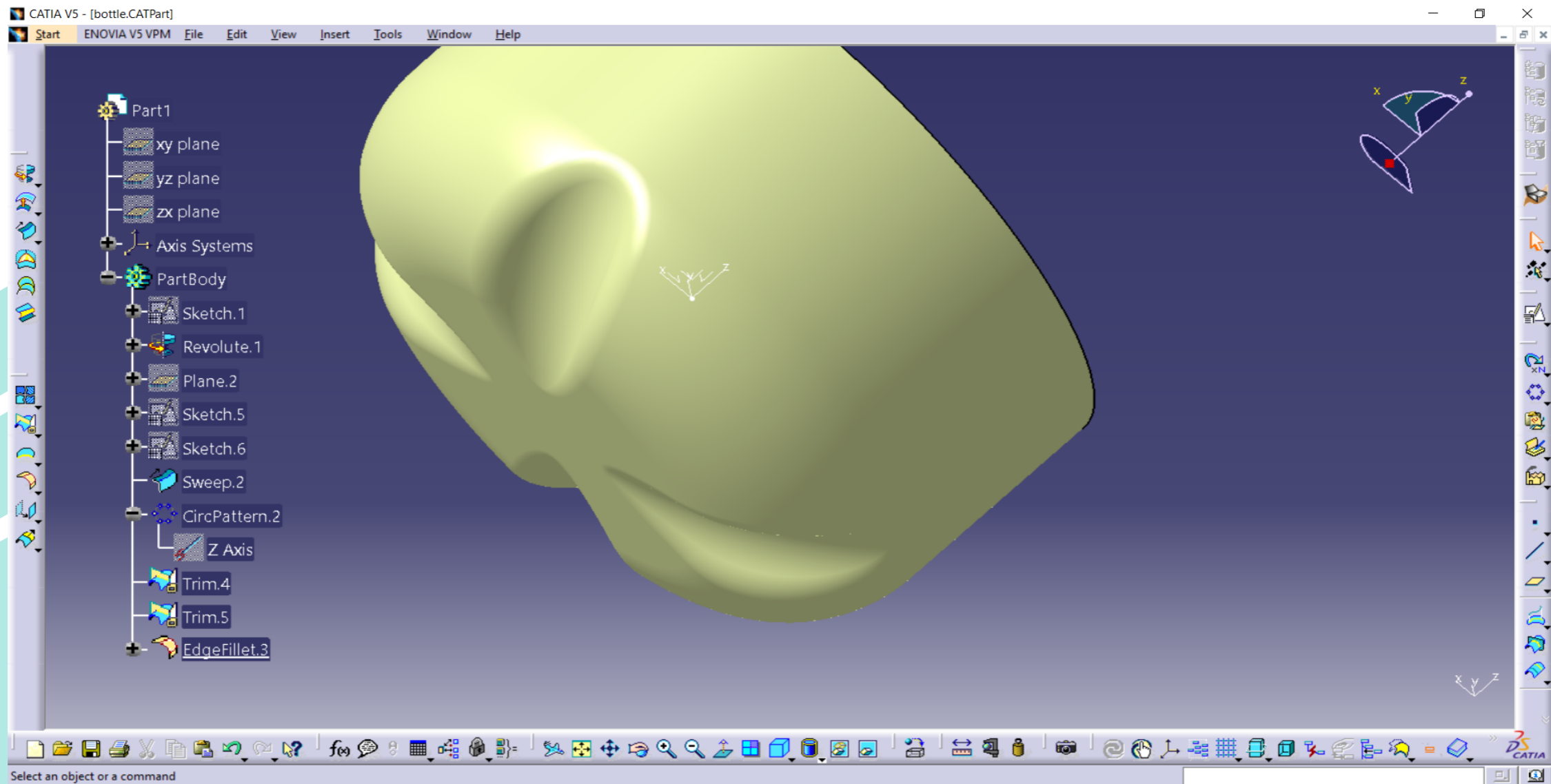

# 3D MODELING A PARAMETERIZED PART IN CATIA V5 (6/8) – EXAMPLE 2

- Draw a new sketch and rotated around z axis at 360deg.

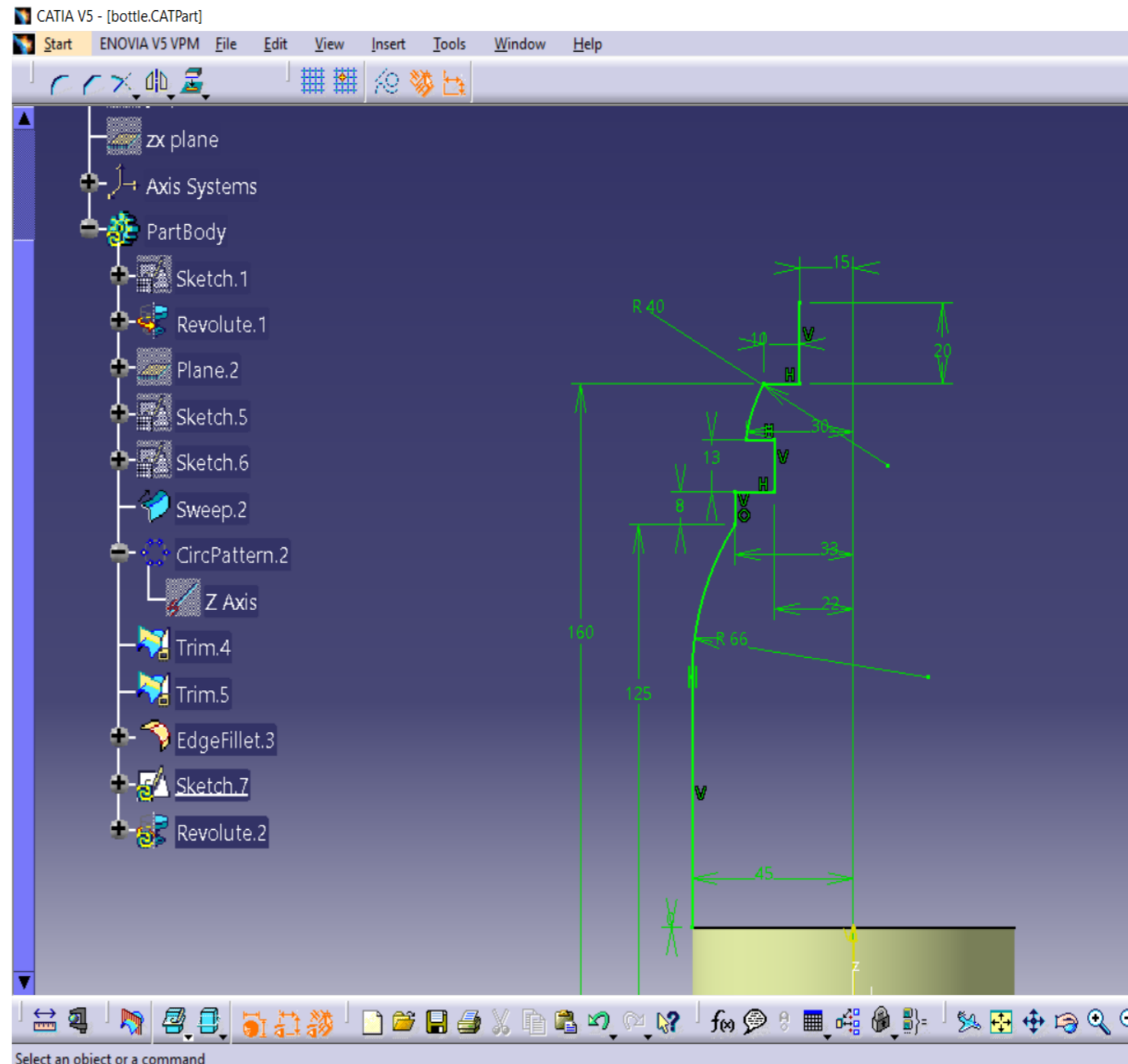

# 3D MODELING A PARAMETERIZED PART IN CATIA V5 (7/8) – EXAMPLE 2

- Draw a helix on the neck of the bottle. Sweep a circle sketch along this helix.

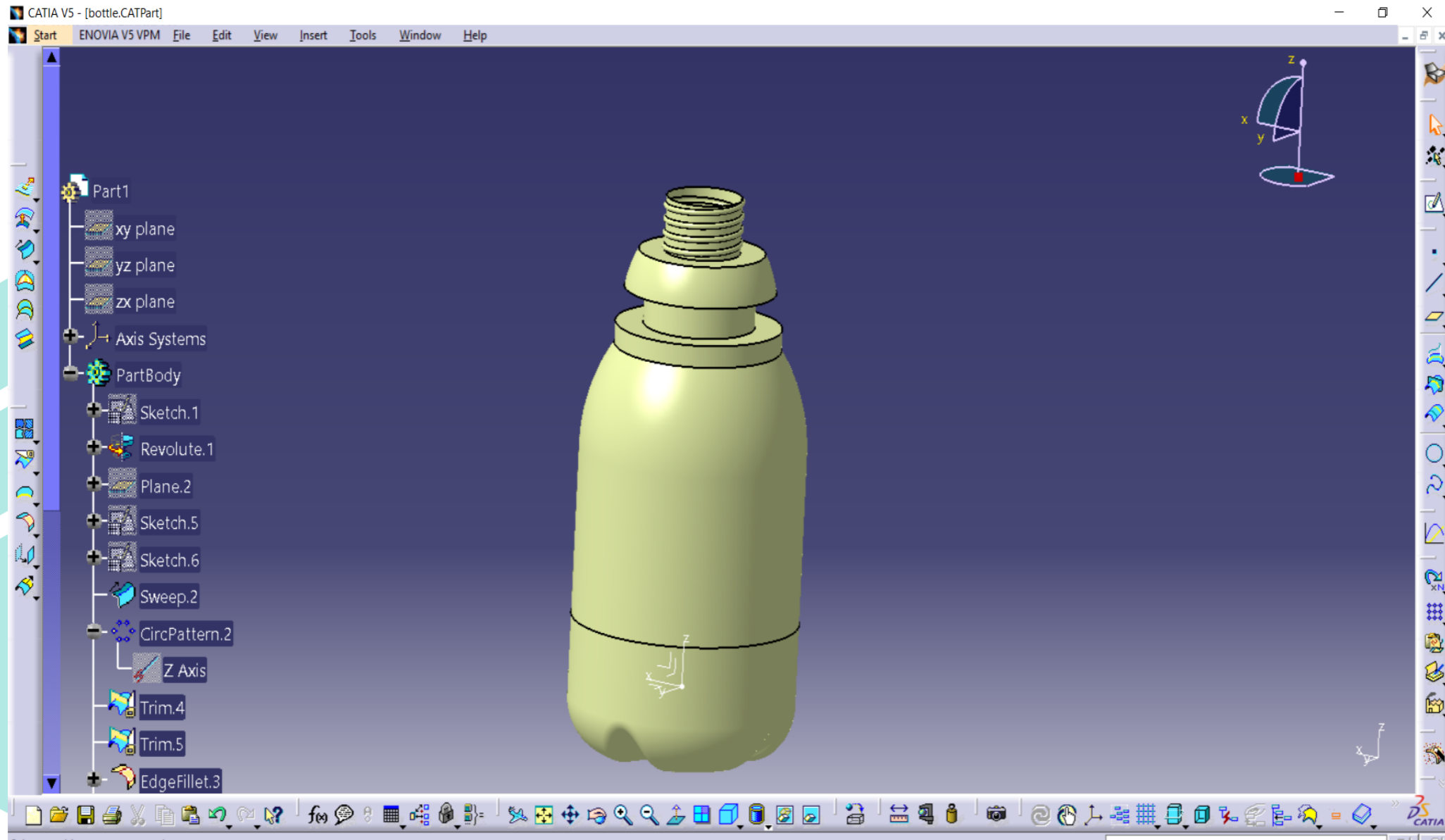

# 3D MODELING A PARAMETERIZED PART IN CATIA V5 (8/8) – EXAMPLE 2

- Join the bottom of the bottle and the trimmed surface. Thicken the surface with 0.75mm.

